



**ROKOSAN<sup>®</sup>**



**ENVIRONMENTAL MISSION of**

# **ROKOSAN Ltd.**

**disposing of poultry feathers into eco-product**  
**liquid organic fertilizer**



# animal WASTE → → RAW MATERIAL

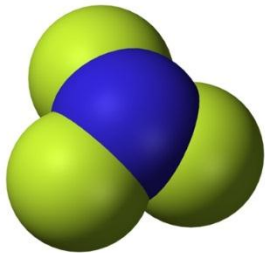
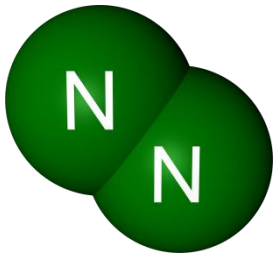
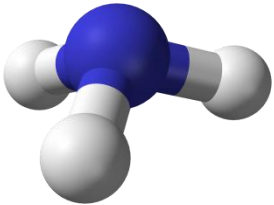

# feathers → Time Bomb ?

- today 8 billion tons of feathers are annually produced in the world poultry industry – this type of animal waste could become in one moment pure source of infections
- although animal waste and its use is being monitored in many countries, there are often some scandals in the public caused by the fact that oversized substances of animal waste get into animal feed and could cause BSE, avian flu which can subsequently lead to culling of farms
- feathers is often used as an ingredient into meat and bone meal, this may sooner or later lead to huge degeneracy problems or may result cannibalism deviance
- putting feathers into meat and bone meal is being preferred in Asia – because of huge consumption of poultry meat, rapid farming and growth of the food chain

# methods of disposing

## INCINERATION

- incineration generates the dangerous emissions / incineration of 1 ton of feathers costs about 70 €
- waste has to be usually transported hundreds of kilometers – this is again expensive and dangerous solution

## LANDFILLING

- from epidemiological point of view, landfilling becomes unacceptable – as know in the past – animal waste could become in once moment source of anthrax
- generally speaking, landfilling causes
  - contamination of ground water, soil and air
  - greenhouse gases

# Landfilling → negative impact on the environment



# H5N1



**incineration generates CO<sub>2</sub>, dioxin, heavy metals, acid gas, fine particles, fly ash and bottom ash**



# waste becomes marketable product



**solution**

# WE HAVE A SOLUTION !

- we offer a streamlined and cost-saving system for disposal of feathers into an ecological product - liquid fertilizer rich on organic nitrogen
- the actual manufacture produces heat as an added value, which can be used in the further production process
- technology helps to participate on National Emission Reduction Program
- „ecological mission“ may prevent the occurrence of diseases already known and new unknown ones, which hit the animals from time to time and cause huge damages to the public health too
- in a wider context, the other benefits are in the subsequent greening and a formation of healthy food and lifestyle

**Our solution offers an elegant way how to dispose 100% of feathers into an ecological fertilizer**

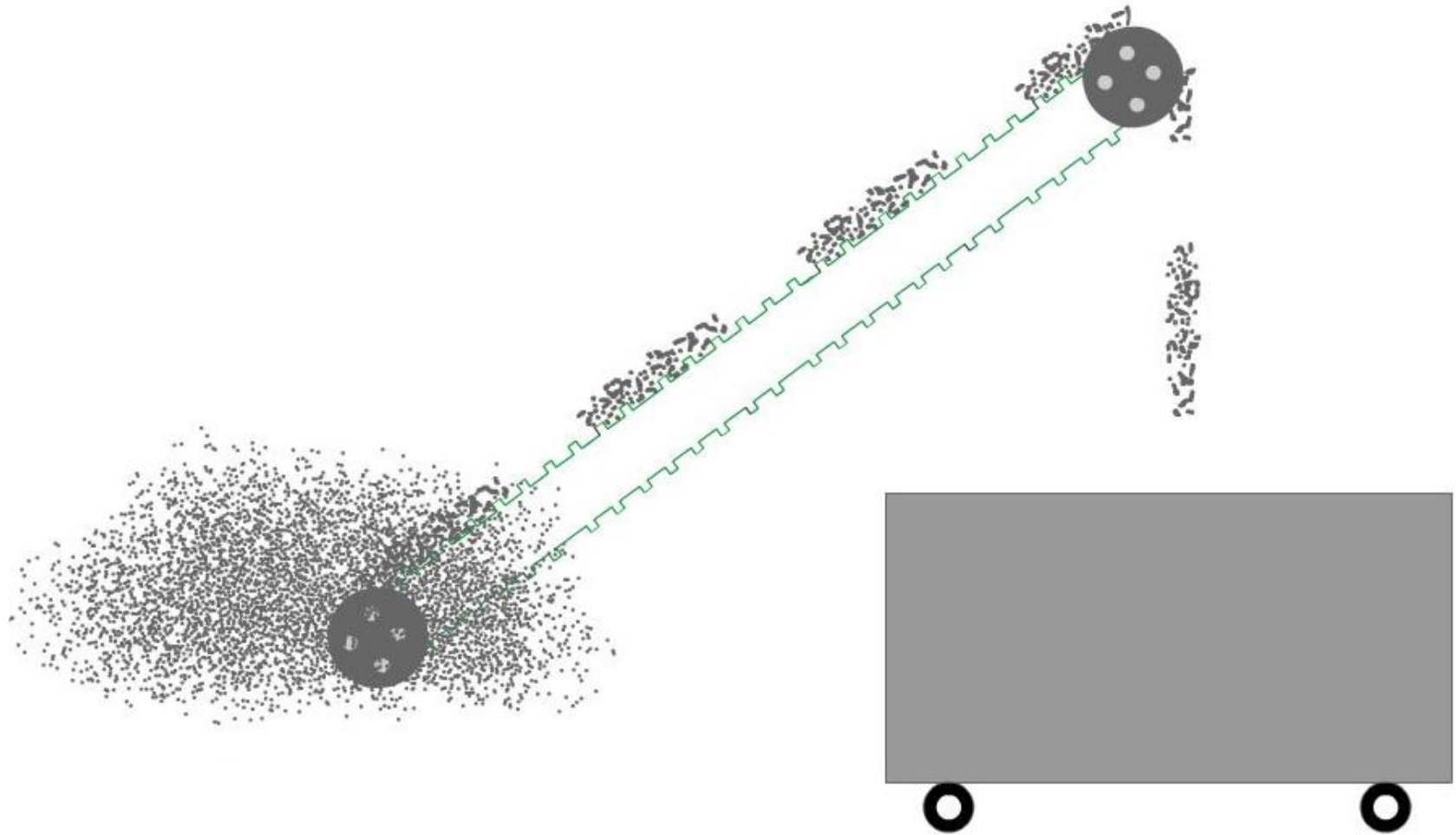

# The process of production of liquid fertilizer starts by filling up a reaction tank with feathers

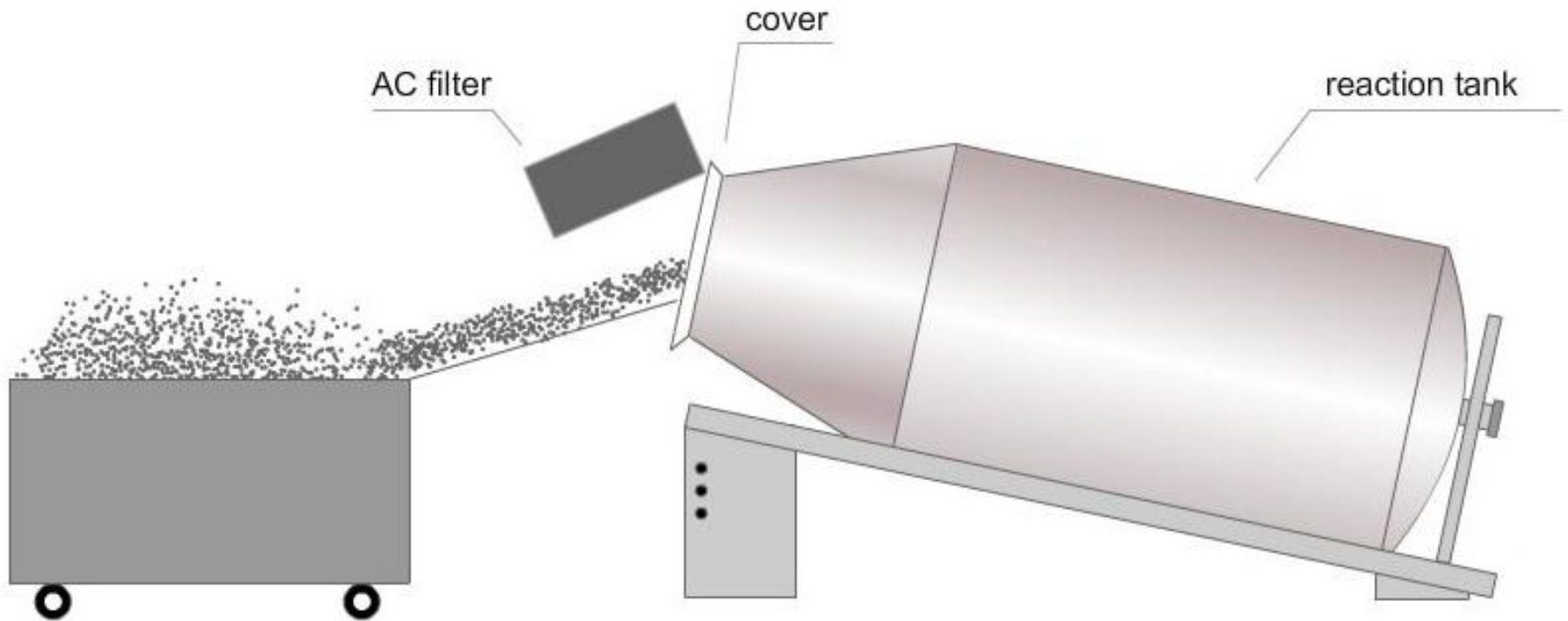

## We add reaction component and close the reactor

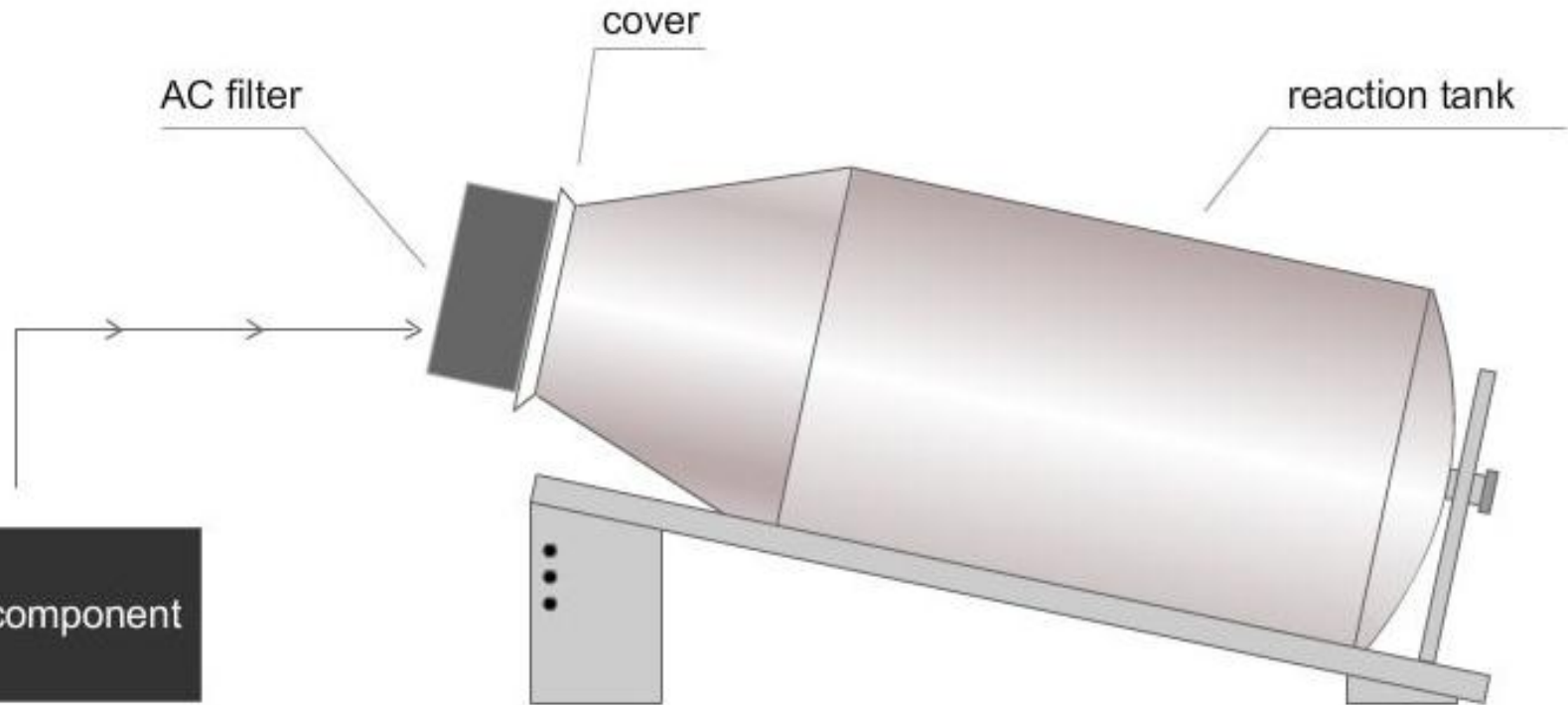

**We add required quantity of WATER and mix it all**

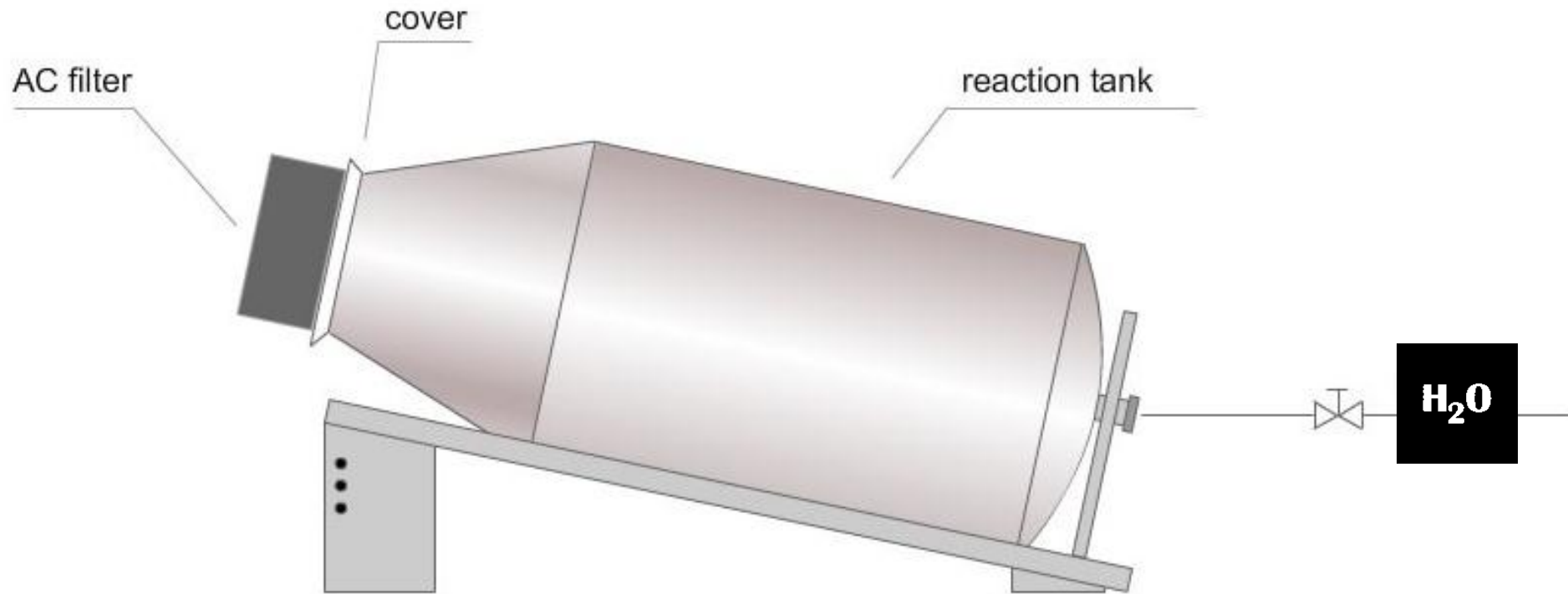

**process of decomposition of feathers starts after the mixture during which the heat necessary for catalysis is generated**

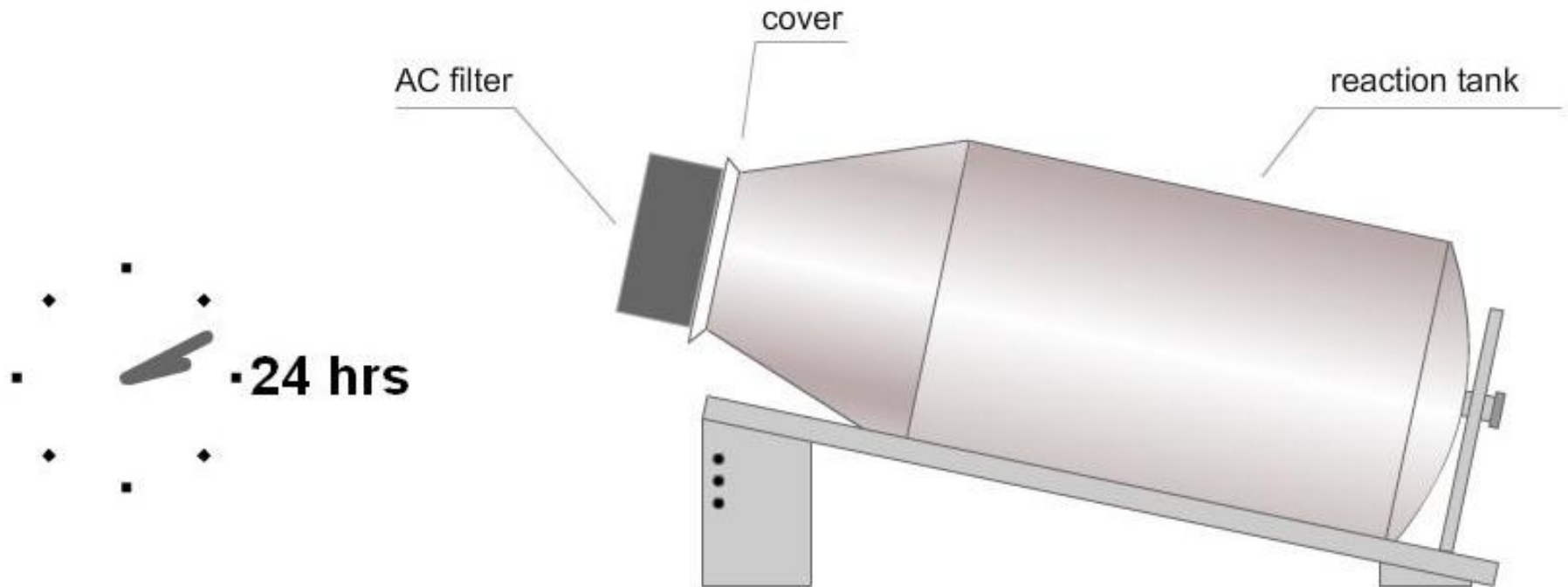

**After hydrolisis we can use the accumulated heat for heating up of operational water**

**During cooling the reactor and neutralization there is also useful heat**

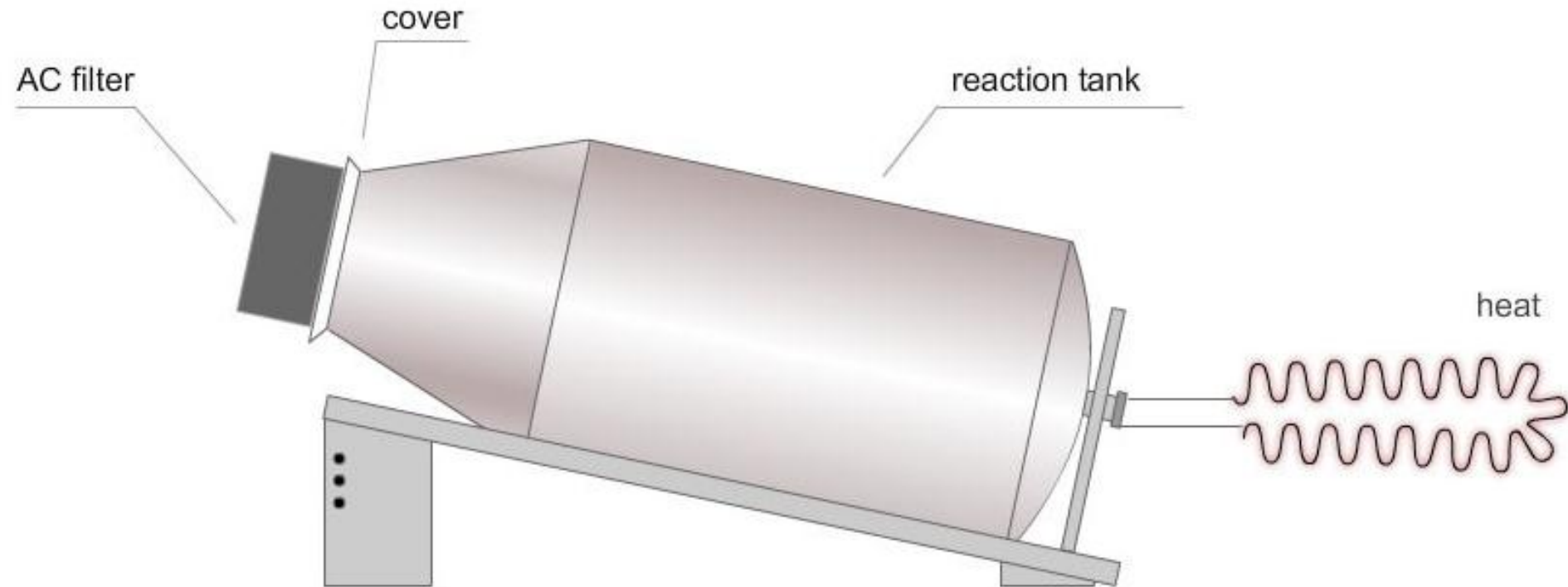

**After cooling down, liquid NPK concentrate can be enriched with other micronutrients according to requirements of different customers**

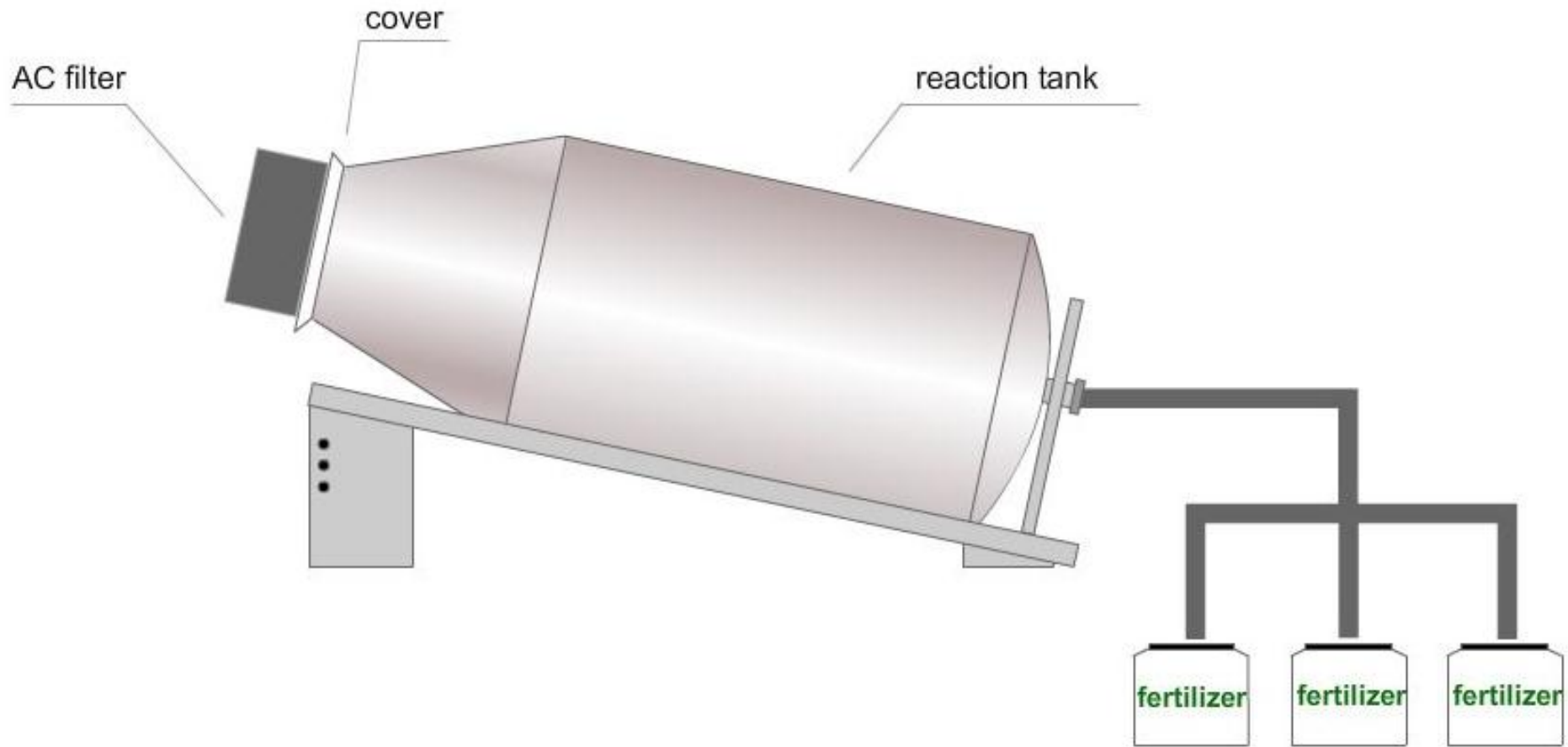

# analysis of NPK concentrate (values in dry matter)

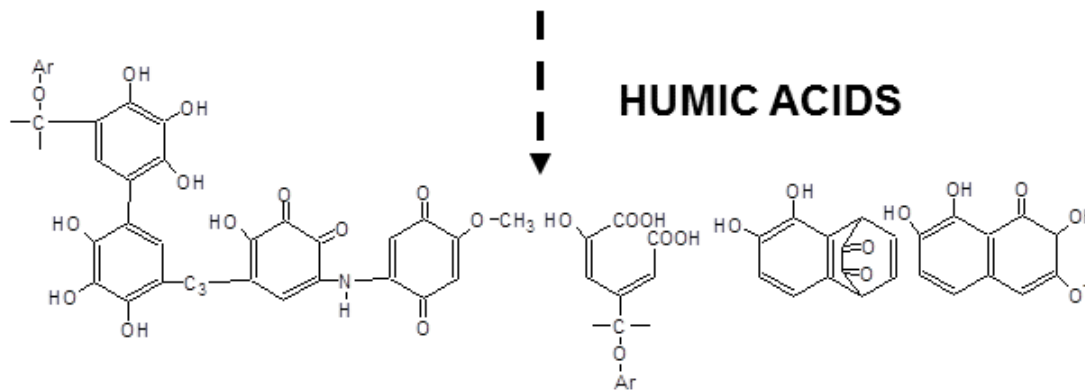
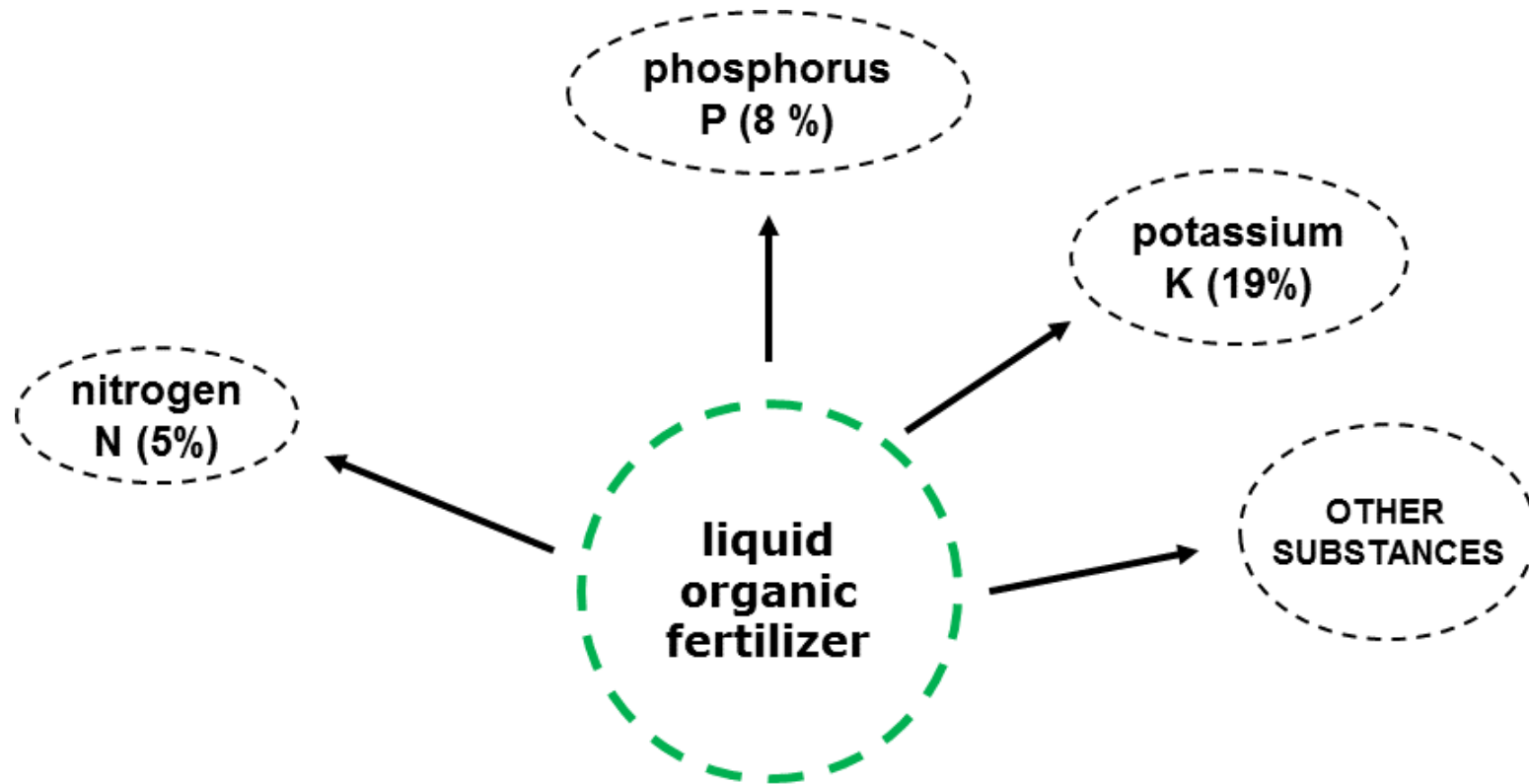

**After required dilution, our product can be applied to the roots of a plant or sprayed on its leaves**

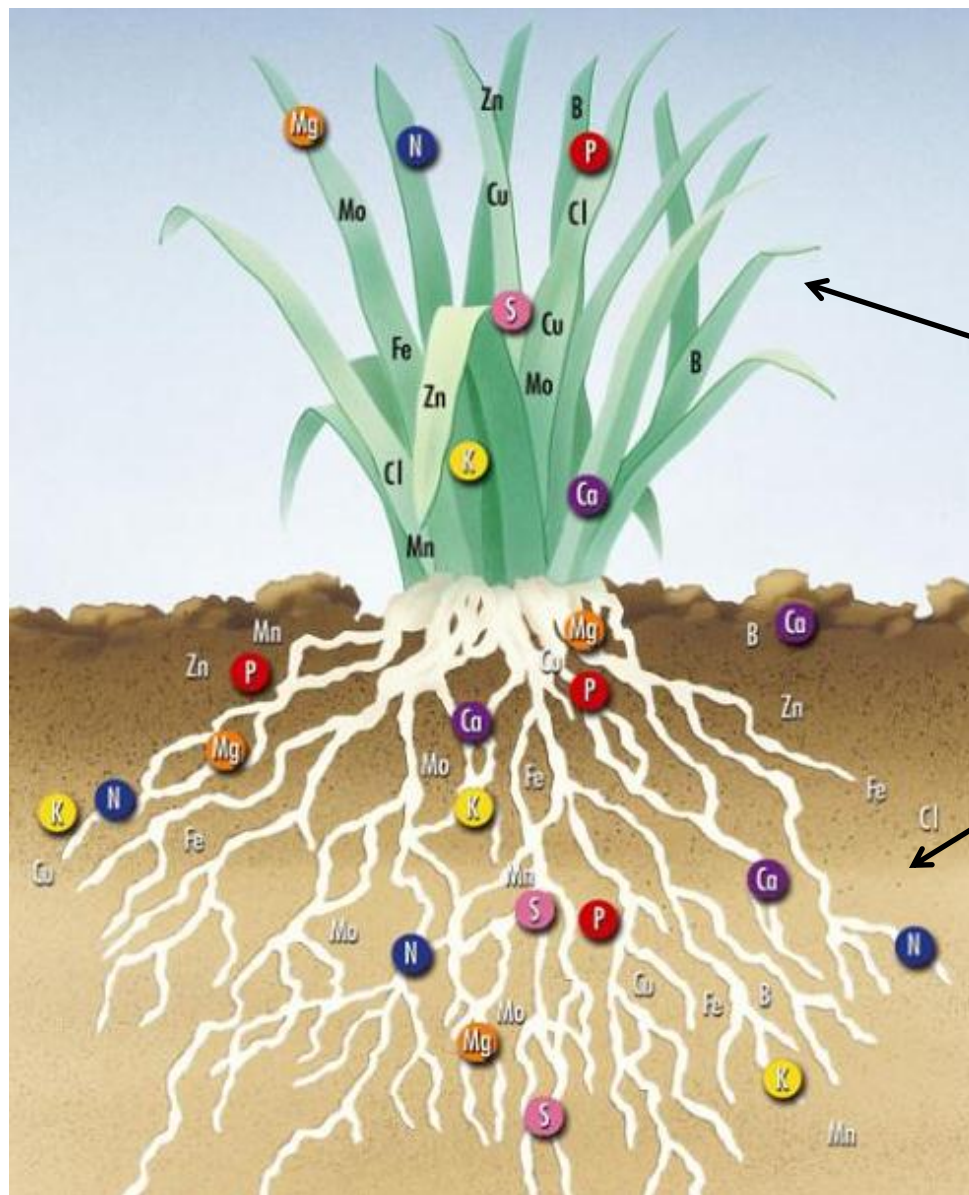

# application of our fertilizers

- „Rokosan“ in colloid form will neither flood nor outflow, it does not contaminate the soil with nitrates

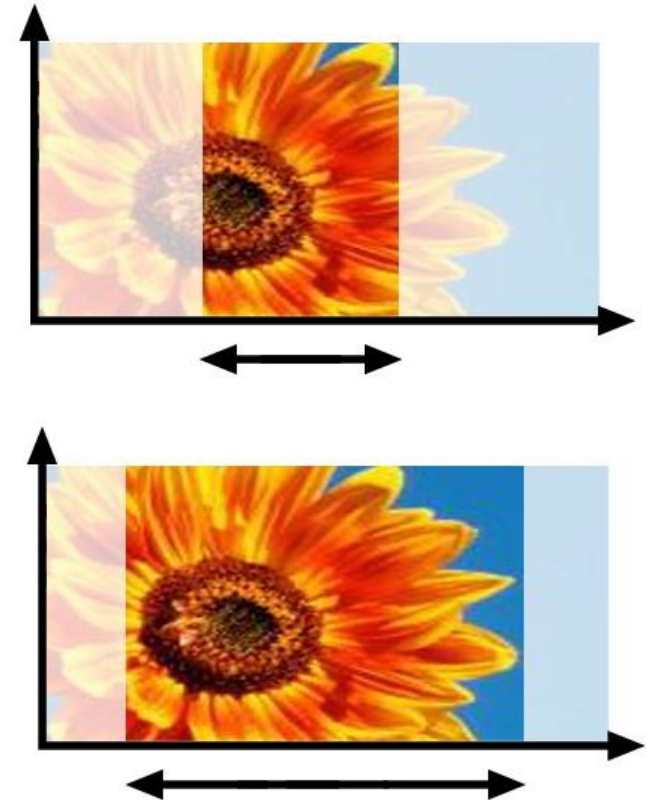
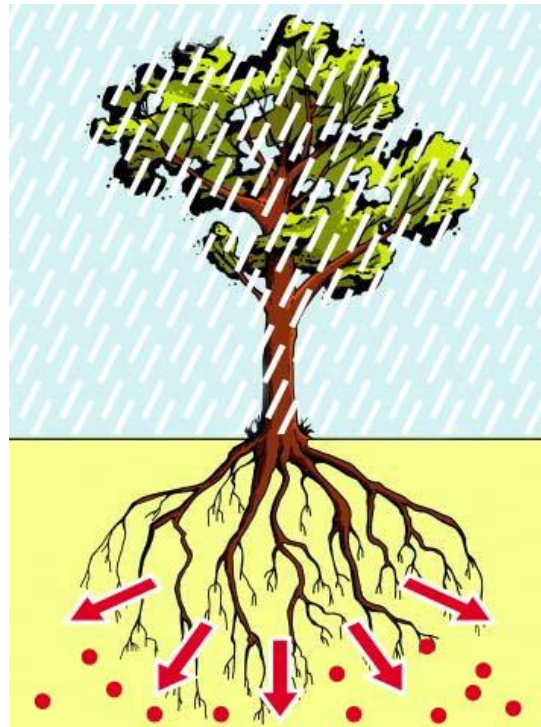

- flower – a rich scale and variety of colours / flashiness and juiciness of the fruit
- plant homogeneity of woodness / stability of growth
- store fertilization / vegetal time is expanded / increased fertility of the fruit
- increased the blooming time of flowers

# Supply of trace elements we achieve production of different types of fertilizers



**ROKOSAN**<sup>®</sup>

# WHO ARE WE ?

- We are group of entrepreneurs which is investing in the sphere of research of organic waste of animal nature
- The offer which we are trying to take your attention to, lies in a more global view – in solving the issues linked to the environment
- Our offer for cooperation is not to sell or distribute our products on your market, but **it is about solving the matter of disposal of feathers**
- The company ROKOSAN is a producer of organic and organic-mineral fertilizer based on the waste of animal nature (feathers). Except that we are ready to supply ecological liquid nitrogen as and input for other production
- Among other things, we can offer solution to the multinational corporations producing fertilizers, which would be interested in greening their technological processes or looking for a cheap source of liquid nitrogen

# Special projects

## Forest revitalization in Slovak republic



## Experiments in People's Republic of China

**ROK HOLD**

... 新千年多功能凝胶型肥料

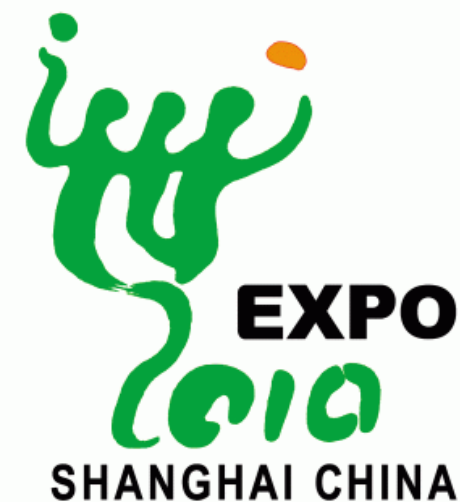

**contact**

**ROKOSAN Ltd.  
SK-07801 Sečovce  
Slovak republic**

**[export@rokosan.sk](mailto:export@rokosan.sk)  
[www.rokosan.sk/en](http://www.rokosan.sk/en)**



**ROKOSAN®**